

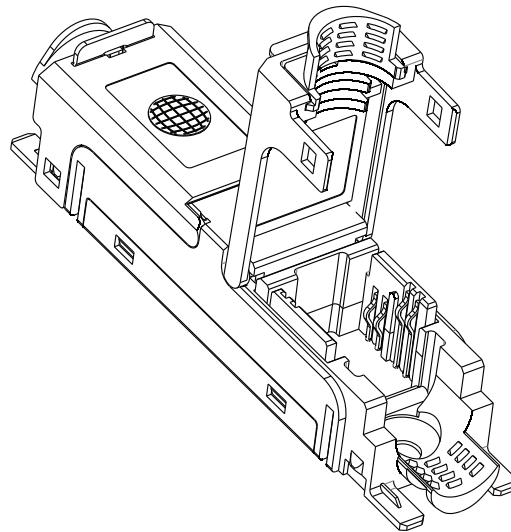

Technisches Datenblatt / technical datasheet

preLink[®] Extender Kat. 6_A ISO/IEC AWG 24 - AWG 22

Artikel Nr. / item No. : CKEA0100



				gez. / drawn	18.02.2015	MJ	 EasyLan [®] ...for a better connectivity
				gepr. / appr.	19.02.2015	GF	
b a	Anpassungen Neuerstellung	20.07.2015 18.02.2015	MJ MJ	Titel / titel:		Maße / Dimensions: mm	
				preLink [®] Extender Kat. 6 _A ISO/IEC AWG 24-22		Original: DIN A4	
Änd./ rev. Index	Änderung/ revision code	Datum/ date	Name/ name	Zeichnungsnummer / drawing number:		Blatt / sheet 1 von / of 4	
				ZN-CU151017			

Technische Daten / Technical Data

Mechanische Eigenschaften		Mechanische Eigenschaften
Leiterdurchmesser	massiv / solid 0,51-0,65 mm / AWG 24/1 - AWG 22/1	Conductor diameter
Kabeldurchmesser	5 - 9 mm	Insulation diameter
Wiederanschließbarkeit (Extender)	≥ 100 Zyklen / cycles	Reusable (Extender)
Wiederanschließbarkeit (Kontaktblock)	0 Zyklen / cycles	Reusable (Connection block)
EG Richtlinie 2002/95/EG (RoHS)	RoHS-konform / RoHS-compliant	EC Directive 2002/95/EC (RoHS)
Werkstoffe		Materials
Gehäuse	Zinkdruckguß / zinc diecast	Housing
Schieber für Zugentlastung	Zinkdruckguß / zinc diecast	Strain-relief slider
Oberfläche	vernickelt / nickel plating	Surface
Platine	FR-4	PCB
Platinenoberfläche	HAL bleifrei / lead free	PCB finish
Kontakte	Federstahl / spring steel	Contacts
Kontaktoberfläche	0,762 µm / 30µin Au	Contact finish
Isolationsgehäuse	PA lichtgrün / light green (RAL 6027)	Insulation housing
Anschlussblock	PC gelb klar / yellow clear	Connection block
Schneidklemmkontakte	CuSn6	IDC
Schneidklemmkontakte Oberfläche	Kontaktbereich / contact area 0,762 µm / 30µin Au	IDC finish
Umweltanforderungen		Environmental Requirements
Schutz vor Fremdkörpern	IP2X	Particulate ingress
Schutz vor Wasser	IPX0	Water ingress
Umgebungstemperatur	-40°C bis / to +70°C	Ambient temperature
Elektrische Eigenschaften		Electrical Characteristics
Kontaktwiderstand	≤ 20 mΩ	Contact resistance
Isolationswiderstand	≥ 500 MΩ	Insulation resistance
Spannungsfestigkeit - Kontakt-Kontakt	≥ 1000 V (DC)	Voltage proof - contact-contact
Spannungsfestigkeit - Kontakt-Schirm	≥ 1500 V (DC)	Voltage proof - contact-shield
Strombelastbarkeit bei 50°C	1,25 A	Current carrying capacity at 50°C
PoE+ gemäß IEEE 802.3at	Geeignet / adequate	PoE+ according to IEEE 802.3at
Transferimpedanz bei 1 MHz	≤ 100 mΩ	Transfer Impedance at 1 MHz
Transferimpedanz bei 10 MHz	≤ 200 mΩ	Transfer Impedance at 10 MHz
Transferimpedanz bei 80 MHz	≤ 1600 mΩ	Transfer Impedance at 80 MHz
Eigenschaften der Übertragung		Transmission Performance
10 Gigabit Ethernet gemäß IEEE 802.3an	Geeignet / adequate	10 Gigabit Ethernet acc. to IEEE 802.3an
Kategorie 6 _A	ISO/IEC 11801; DIN EN 50173-1	Kategorie 6 _A
Klasse EA	max. Linklänge beträgt 90 m / max. length of link is 90m	Class EA

				gez. / drawn	18.02.2015	MJ	
				gepr. / appr.	19.02.2015	GF	
				Titel / title:			
				preLink [®] Extender Kat. 6 _A ISO/IEC AWG 24-22			
				Zeichnungsnummer / drawing number:			Maße / Dimensions: mm
				ZN-CU151017			Original: DIN A4
							Blatt / sheet 2 von / of 4

Änd./ rev. Index	Änderung/ revision code	Datum/ date	Name/ name
b a	Anpassungen Neuerstellung	20.07.2015 18.02.2015	MJ MJ

Zeichnung / Drawing

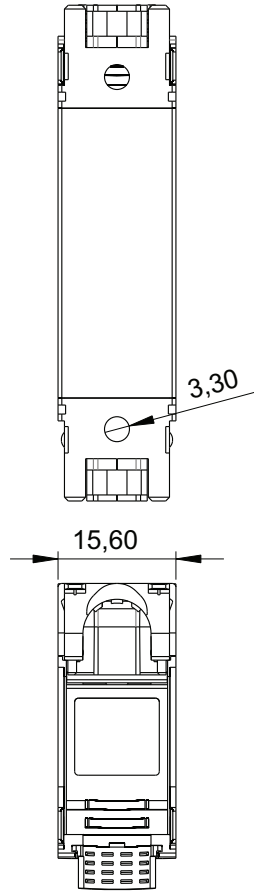
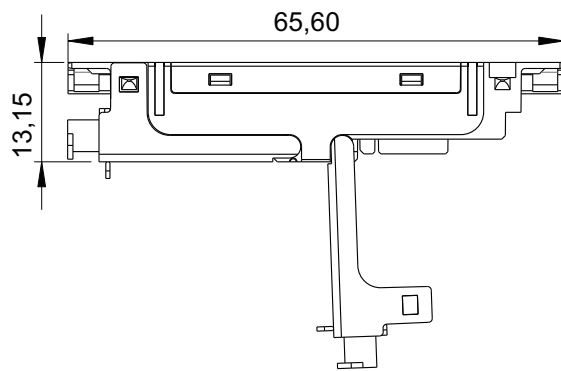
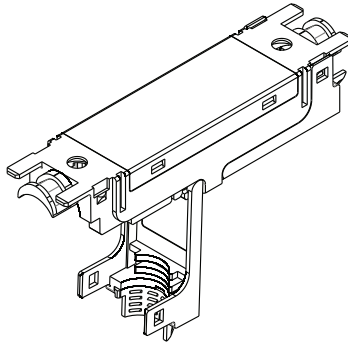
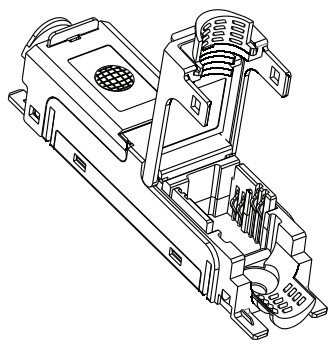

Maßstab / Scale 1:1

b a	Anpassungen	20.07.2015	MJ	gez. / drawn	18.02.2015	MJ	 EasyLan [®] ...for a better connectivity
	Neuerstellung	18.02.2015	MJ	gepr. / appr.	19.02.2015	GF	
Titel / titel: preLink[®] Extender Kat. 6_A ISO/IEC AWG 24-22				Maße / Dimensions: mm			
Zeichnungsnummer / drawing number: ZN-CU151017				Original: DIN A4			
Änd./ rev. Index	Änderung/ revision code	Datum/ date	Name/ name	Blatt / sheet 3 von / of 4			

Zeichnung / Drawing

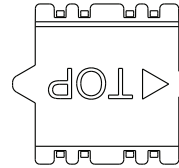
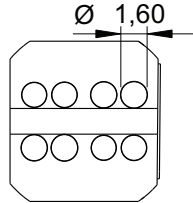
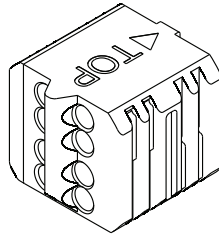

Maßstab / Scale 2:1

Belegung / Configuration

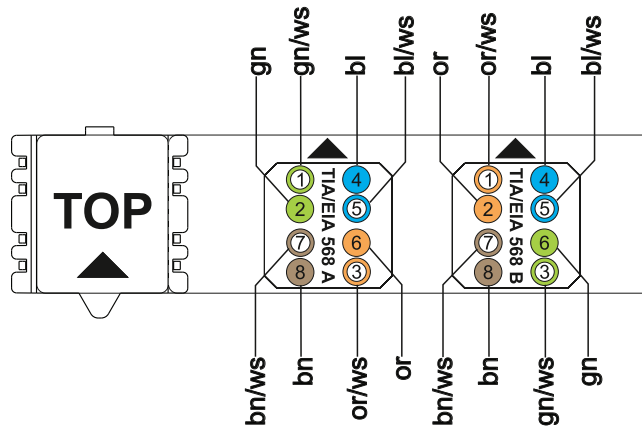

b a	Anpassungen Neuerstellung	20.07.2015 18.02.2015	MJ MJ	gez. / drawn	18.02.2015	MJ	EasyLan [®] ...for a better connectivity			
				gepr. / appr.	19.02.2015	GF				
				Titel / titel:				preLink [®] Extender Kat. 6 _A ISO/IEC AWG 24-22		
				Zeichnungsnummer / drawing number:				ZN-CU151017		
Änd./ rev. Index	Änderung/ revision code	Datum/ date	Name/ name	Maße / Dimensions: mm			Original: DIN A4			
				Blatt / sheet 4 von / of 4						